

## StarTOC Solids Plus Analyzer

**Solids**

**Slurries**

**Sludge**

**Liquids**

### Features

*n Stand Alone with Dual NDIRs*

*n Dual Reactors*

*n Automatic Boat Injection*

*n Scale with Computer Interface*

*n TOC - Direct*

*n TOC-Differential*

*n Configurable Sample Size*

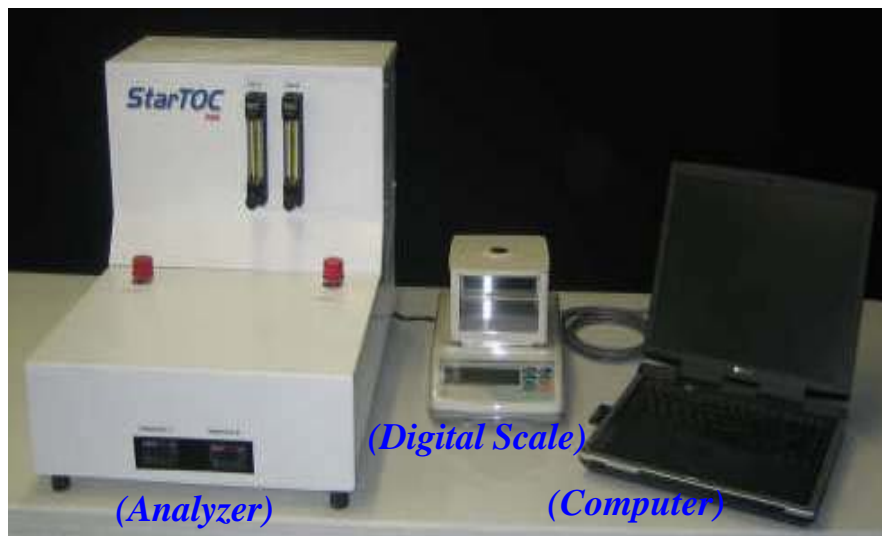

**A True, Stand-Alone Solids, Slurries, Sludges & Liquids Analyzer  
(Not Just an "Add-On" Module)**

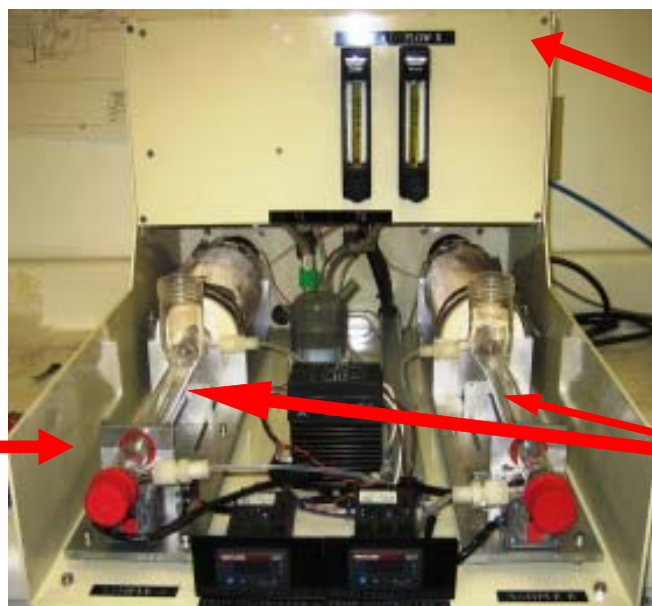

**Description:** StarTOC Solids/Liquid Analyzer provides a platform, which may be configured for a variety of applications, combustion temperatures, catalyst/non-catalyst choices and different Regulatory and Standard Methods. It is an ideal tool to support current development programs, as well as providing capability for any future mandated requirements.

## Applications (partial)

- Solids, Slurry, Particulated Liquids
- Cleaning Validation (Swab Method)
- Combustors/Hazardous Waste Emissions
- Incinerator Residue
- Groundwater/Soil Contamination
- Agricultural Studies/Planning

## Configurations

The hardware provides the operator with a high degree of flexibility to improve the configuration parameters, such as temperatures, reactor catalyst choices or a non-catalytic reaction. The following two (2) methods are currently preferred.

- **TOC - Direct Mode**

This method uses a single, dual-zone heated Reactor. The operator acidifies the sample, which is initially introduced to the 250°C heat zone, where all TIC is vaporized to CO<sub>2</sub> and measured as TIC. After TIC vaporization, the sample is automatically placed in the high temperature heat zone, where the TIC-Free sample is oxidized to CO<sub>2</sub> and reported as TOC.

- **TOC Differential Mode**

This method uses one Reactor, set to a high temperature, to combust all the carbon in the sample, to be reported as TC (Total Carbon).

Another portion of the same sample is acidified and introduced to the Second Reactor, set to 250°C and is reported as TIC. The computer mathematically subtracts the TIC analysis from the TC analysis to derive

TOC:

$$\text{TOC} = \text{TC} - \text{TIC}$$

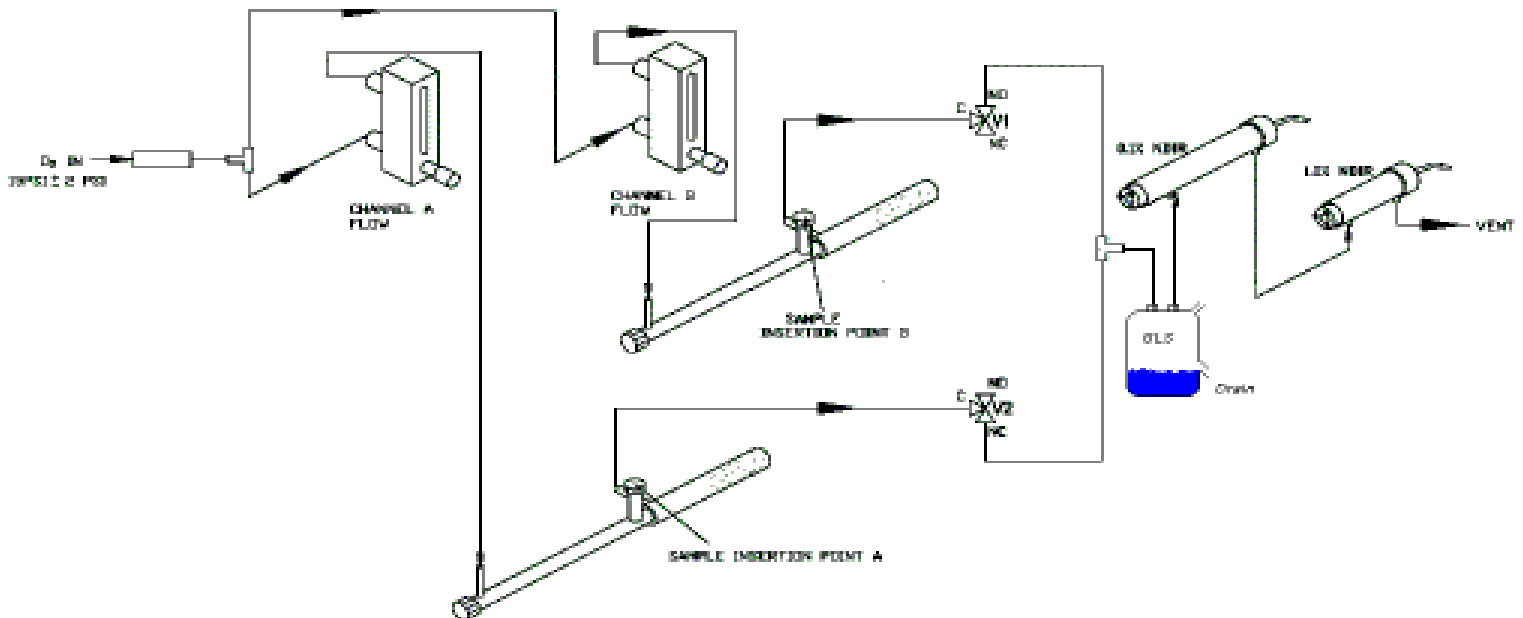

Flow Diagram

## Operation (Solids, Slurry, Sludge)

1. Weigh Sample  
(Sample Weight Automatically Entered)
2. Enter Solids Fraction (Operator)
3. Enter Sample Tag (Operator)



4. Position Crucible on injector



5. Sample Automatically Injected

6. Automatic Analysis

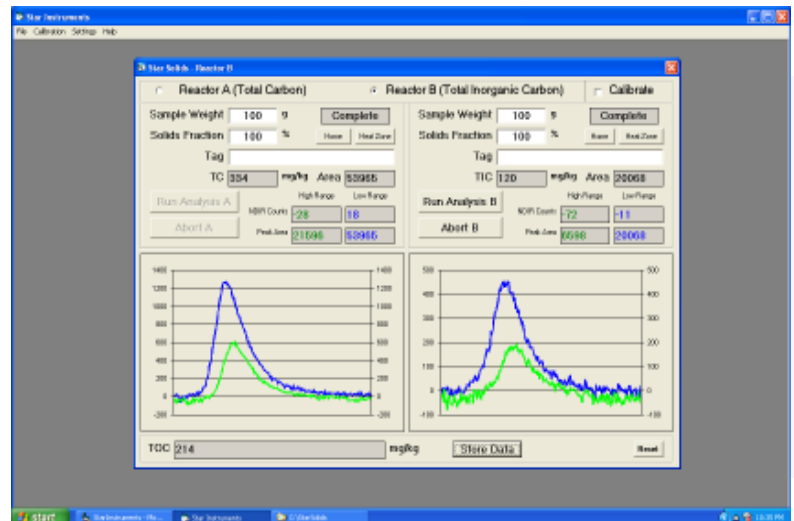

## Operation (Liquids)

1. Dispense Specified Amount of Sample by Syringe
2. Perform Same Functions as with Solids Analysis (above)



## **Specifications: (Nominal)**

<b>Sample Size</b>	<b>Configurable</b>
<b>Reactor Temperature</b>	<b>Adjustable up to 1000°C</b>
<b>Range</b>	<b>Set by Operator</b>
<b>Response Time</b>	<b>From 5 - 7 minutes (nominal)</b>
<b>Power Supply</b>	<b>110/220 VAC 10 Amp service recommended</b>
<b>Dimensions (HxWxD)</b>	<b>17 x 17 x 24 in. 43 x43 x 61 cm.</b>
<b>Weight</b>	<b>40 lbs 18 kg</b>

## **Purchase Specifications:**

- A) The Analyzer shall measure TOC and/or TIC in solids, slurries, sludge & liquids.**
- B) It shall have dual Furnaces & dual Reactors, each having operator temperature adjustments up to 1,000°C.**
- C) It shall have an independent automatic sample injection system on each Reactor, to eliminate rate of oxidation errors caused by non-regulated sample injection speed.**
- D) It shall incorporate Dual Solid State, Dual Wavelength Ratioing, Non-Dispersive Infrared Analyzers (NDIRs) to measure the Carbon Dioxide (CO<sub>2</sub>) generated in the oxidation phase of analysis. The NDIRs shall be completely computer controlled and have no moving parts. It shall have a non-reflective, borosilicate sample cell, impervious to corrosion and be self-calibrated. It shall carry a 5 Year Warranty on the NDIR Sample Cell & a 2 Year Warranty on the Complete NDIR Bench.**
- E) High Temperature Combustion Method fully compliant with EPA 415.1 shall be used.**
- F) All software shall be included to operate the analyzer for both “TOC-Direct” & TOC-Differential”. Software shall be easily installed on customer-furnished P.C. (or Star to provide P.C. as an Option). Software to be supported for life of the analyzer.**
- G) Star Part Number TB200, Digital Scale shall be furnished (Option). Digital Scale to be interfaced to P.C. to record sample weight automatically to maximize precision of analysis.**
- H) Analyzer shall be Star Instruments Model “StarTOC-Solids, Slurries, Sludge & Liquids” Analyzer.**

# **TOC SYSTEMS' OTHER BENCHTOP ANALYZER SYSTEMS**



## **AUTOMATIC TOC/TN ANALYZER**

**A Truly Automatic TOC Analyzer offering Five Oxidation Methods, 103 Sample & 1 Wash Stations, Septum Piercing Vortex Stirrer, Dual NDIRs & Easy Operation with Windows Software.**



## **SEMI-AUTOMATIC BENCHTOP TOC ANALYZER**

**UV/HEATED PERSULFATE METHOD**

**&**

**HIGH TEMPERATURE COMBUSTION METHOD**

**A low-cost, accurate TOC analyzer utilizing components and software from TOC Systems' family of computer-controlled automated TOCs. Very simple operation and maintenance. May be the analyzer of choice when less than 30 samples per day are to be analyzed.**



## TOC Systems, Inc. also Offers Complete On-Line Analyzer & Sample Systems

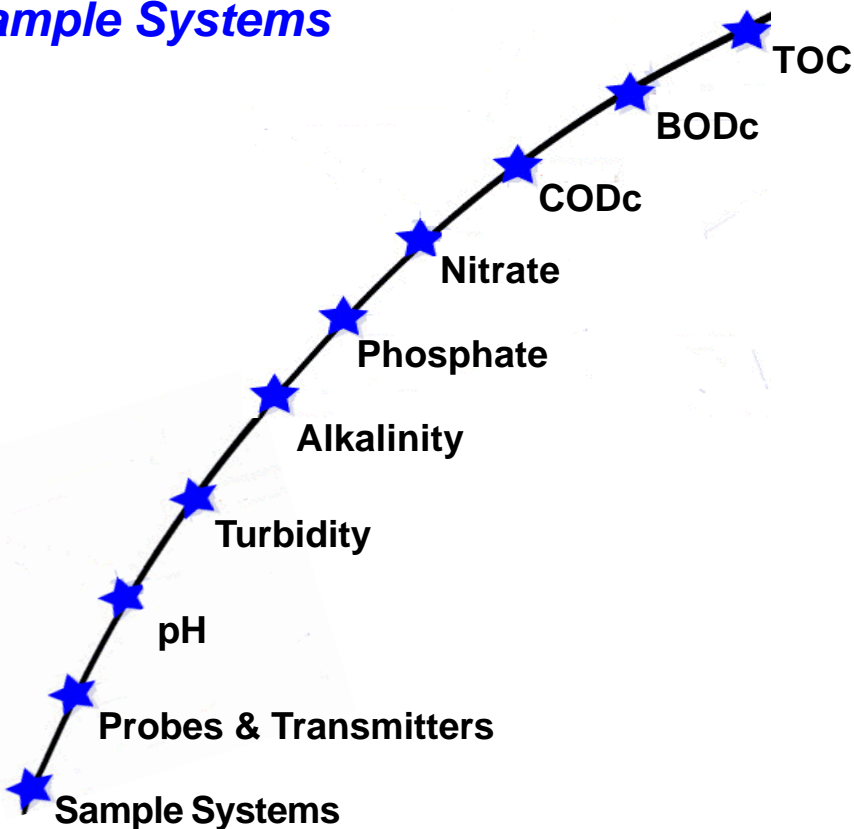

*"Committed to keeping you on-line."*



**TOC SYSTEMS, Inc**  
100 Park Avenue  
League City, TX 77573 USA  
Phone (281) 338-1388  
Fax (281)332-5609  
Email: [sales@tocsystemsinc.com](mailto:sales@tocsystemsinc.com)

## Pre-Engineered On-line System Packages and Enclosures

TOC Systems also provides pre-engineered and custom systems, including small shelters with all utilities installed and ready to be delivered to your site.

- Effluent Monitoring
- Waste Treatment
- Drinking Water
- Process Monitoring
- Panels & Small Shelters
- Custom Packages

